

Mixing tank



Waste water



Drinking water



Air & smoke

Powder chemical slurry preparation or suspension unit

In addition to its dry chemical discharge and feed system, Sodimate also provides a complete mixing tank for all types of slurries.

Each slurry tank is specifically designed for our customer and the dry chemical they need to dilute and mix.

The volume is calculated according to your basic slurry requirements (pumping throughput and concentration of the slurry) and your process pumping mode (by batch or continuous).

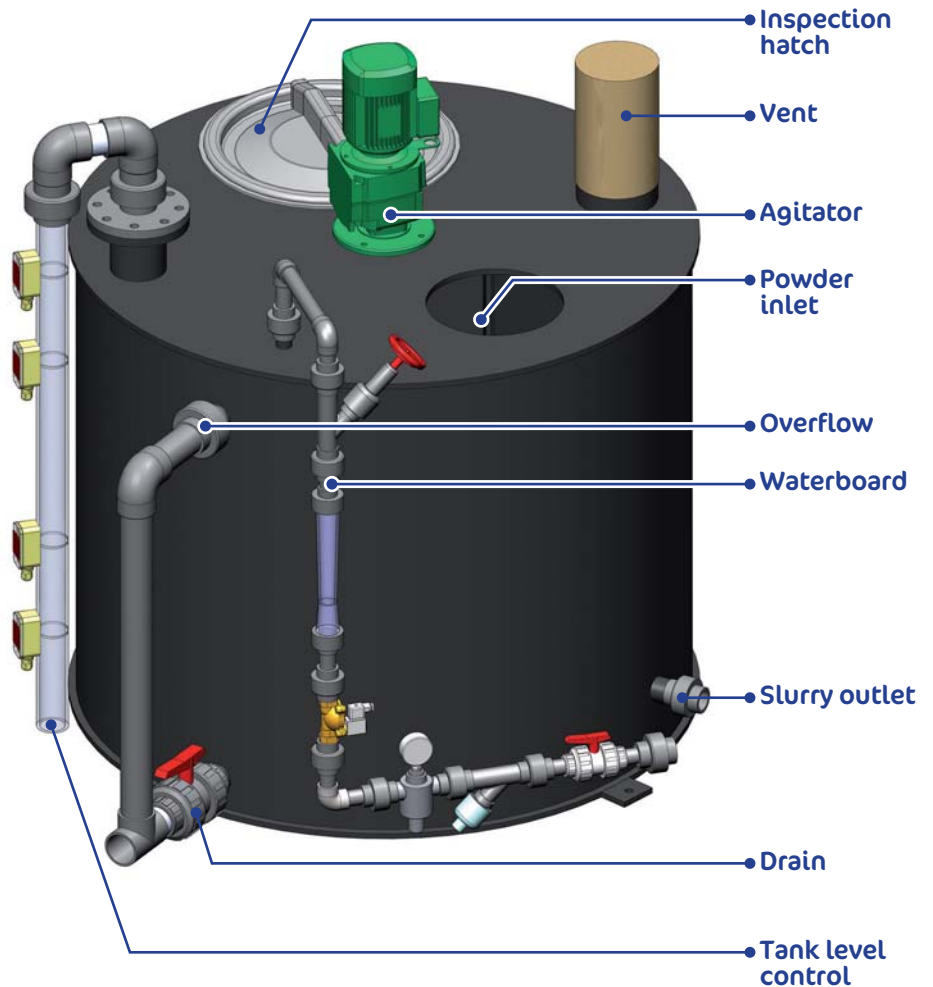

Advantages :

- Tank design adapted to the specific needs
- Tank integrated in turn-key solutions
- Dust free unit (fully sealed equipment)
- Designed especially for lime and activated carbon
- Low maintenance
- Long time experience

Examples of setting-up :

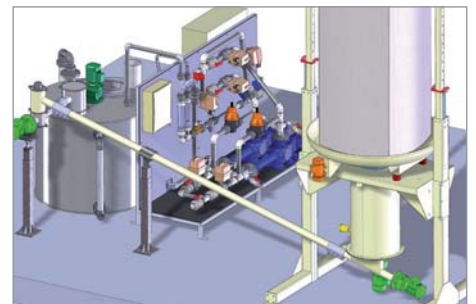
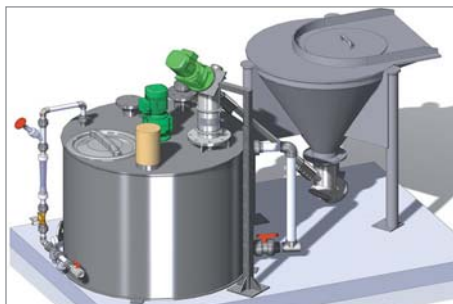

Operation :

Our tanks are especially designed for lime milk preparation and activated carbon suspension, which concentration varies from 50 to 150 g/l.

These tanks are made of black HDPE and are equipped with agitator, waterboard (with solenoid valve and flowmeter), level control system (high level, "product call" level and low level) and all connections necessary for the slurry pumping and draining.

Antivortex blades are also installed inside the tanks as they necessary to guarantee the homogenous mixing of the prepared slurry.



Options :

- **Vent with spraying nozzle (dust removal)**
- **Sodimix** (dust free activated carbon high shear mixer)
- **Radar or ultrasonic tank level control**
- **Design for recirculation loop**
- **Special design for high concentration (more than 150 g/l)**
- **Digital flowmeter**
- **Non standard tanks : special size and shape upon request**

Example of standard tank sizes				Overall dimensions
Total volume (L)	Working volume (L)	Ø (mm)	H (mm)	L X W X H (mm)
500	400	800	1000	1100 x 1100 x 1500
1000	900	1200	1000	1500 x 1500 x 1500
1500	1350	1450	1000	1600 x 1600 x 1500
2000	1800	1450	1300	1600 x 1600 x 1800